

BRONZE RUBBER IMPELLER PUMP

MODEL
402M



OBARDORFER PUMPS
A Subsidiary of Thomas Industries Inc.

PIPE SIZE 1 1/4 I.D. HOSE SLIP ON



CAPACITY Water at 60°F

Pump	RPM	Feet Hd.	0	20	40	60	80
		PSI	0	8.7	17.3	26.0	34.6
402M	800	GPM	12.0	11.0	9.7	7.5	2.0
		HP	1/3	1/3	1/2	1/2	3/4
	1750	GPM	25.0	24.0	22.2	19.1	15.0
		HP	3/4	3/4	3/4	1	1
402M-03	2500	GPM	32.5	30.5	27.0	24.0	17.5
		HP	1	1 1/2	1 1/2	2	2
	3000	GPM	36.0	34.5	31.0	27.5	21.0
		HP	1 1/2	1 1/2	1 1/2	2	2

DO NOT RUN DRY

Rubber impellers generate high rubbing friction unless lubricated by liquid pumped. Lack of liquid will cause impeller to burn up.

DRIVE

Select proper belt size to match pulley groove as shown on dimension drawing on back. Belt must run sufficiently tight to prevent slippage. Do not overtighten.

LIQUIDS AND TEMPERATURE

Liquids compatible with neoprene can be pumped including fresh and salt water solution and mild chemicals. Do not pump severe solvents or acids. When possible flush pump with fresh water after each usage.

Extremes of cold and heat will affect impeller life. Limits of 40° to 140° F should be observed. Do not allow liquid in pump to freeze. Drain pump by loosening cover screws. Use methyl alcohol based anti-freeze compounds such as Zerex, Shell Zone, Pyro Permanent, Permagard, Dowgard.

SUCTION LIFT

Suction lift of 15 ft. is possible when impeller is wet. Suction lines must be air tight in order for pump to self prime.

IMPELLER REPLACEMENT

The impeller must be replaced if it is worn out or has been damaged by debris or by running the pump dry. Symptoms of a defective impeller are low pumping pressure and low flow causing overheating of the boat engine. Poor pump performance can also be caused by slippage of V-belts, so belts should be checked for tightness.

To replace the impeller remove screws and cover. Pull out the impeller with nose pliers or two screwdrivers. Be careful not to dent the pumping chamber with these tools. When inserting new impeller, line up key slot in impeller with the key in the shaft. Use oil on shaft and avoid forcing the impeller onto the shaft.

The impeller should also be removed for storage periods to prevent the blades from taking a permanent set. (continued on back)

DESIGNED FOR DAYTONA MARINE ENGINE USING CHEVROLET BLOCKS No. 327 AND 427. DESIGNED FOR AMERICAN MARINE LTD. USING JOHN DEERE BLOCK No. JD6404 DR-15 AND GMC BLOCK TOROFLOW 63701893. ADAPTABLE TO OTHER ENGINES USING THESE BLOCKS.

FEATURES

- Bronze Construction - Corrosion Resistance
- Reversible Wearplate
- Teflon® Barrier Seals Protecting Ball Bearings
- Mechanical Carbon Ring, Ceramic Face Main Pump Seal
- Two Sealed Ball Bearings Spaced for Maximum Load Ability
- Large Vent & Drain Openings Separate Seal & Bearing Areas
- Shaft Slinger for Additional Bearing Protection
- Neoprene Impeller
- High Chrome Nickel Stainless Steel Shaft
- O-Ring Seal Between Body and Cover Eliminates Gasket Problems
- Impeller & Cam Easily Replaced

MOUNTING

Pump will operate satisfactorily when mounted in any position. Special mounting holes are provided as part of extended cover casting.

ROTATION

Direction of shaft rotation determines inlet and outlet ports (see dimension drawing on back). Prior to installation, rotate the pump manually in direction of rotation to set flexible blades in direction desired.

*Teflon® is a registered trademark of DuPont. Teflon® or equivalent PTFE will be used.

MODEL
402M

BRONZE RUBBER IMPELLER PUMP

OBERDORFER PUMPS
A Subsidiary of Thomas Industries Inc.

SECTION VIEW AND PARTS LIST

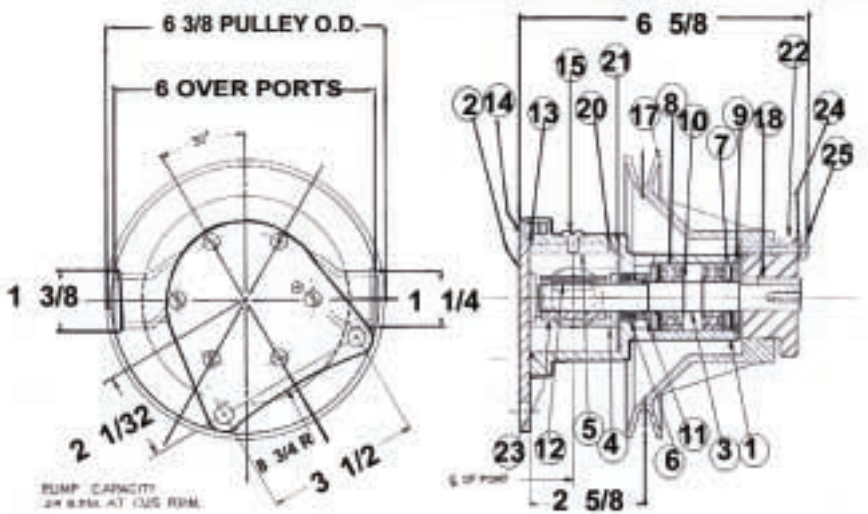

Pump No.	1	2	3	4 ¹	5	6 ¹	7	8	9	10	11	12
	Body	Cover	Shaft	Impeller	Cam	Seal Assy.	Lip Seal	Bear'g	Snap Ring	Snap Ring	Washer	Key
	1 Reqd	1 Reqd	1 Reqd	1 Reqd	1 Reqd	1 Reqd	2 Reqd	2 Reqd	1 Reqd	2 Reqd	1 Reqd	1 Reqd
402M	6658	6659	6637	6603	6606	32230	6609	5928	5925	5926	6631	5475
402M-03	6658	6659	6637	6603	6606	32230	6609	5928	5925	5926	6631	5475

13 ¹	14	15	16	17	18	19	20	21	22	Repair Kit ¹
O-Ring	Screw	Screw	Washer	Pulley	Key	Bush'g	Pin	Plate	Screw	
1 Reqd	6 Reqd	1 Reqd	3 Reqd	1 Reqd	1 Reqd	1 Reqd	1 Reqd	1 Reqd	3 Reqd	
6684	6775	7300-62	---	---	6567	---	6685	6635	---	10653
6684	6775	7300-62	5016	6661	6567	6931	6685	6635	6958	10653

¹ Repair Kit contains items 4, 6 & 13.

PULLEY

The pulley is normally installed at the factory. If field service requires pulley removal and reinstallation, proceed as follows:

Pulley Removal: Loosen and remove the three (3) cap screws in the tapered steel bushing. Thread the 3 cap screws in the tapped removal holes, and progressively tighten each one until the aluminum pulley is loose on the tapered steel bushing. If the steel bushing won't slip off the pump shaft, wedge screwdriver blade in saw cut to expand and overcome tightness.

Pulley Installation: Align the pulley groove with the belt centerline. Tighten the 3 bushing cap screws drawing the tapered steel bushing into the aluminum pulley and thereby tightening the steel bushing onto the pump shaft. Tighten the screws evenly and progressively. This insures an even draw down to eliminate pulley wobble. DO NOT tighten each screw independently. The ultimate maximum recommended torque is 75 inch-lbs.

DIMENSIONS

(continued from front)

SEAL REPLACEMENT

If water drips from the weep hole or from the area where the shaft exits the pump, the seal is defective and must be replaced. While the Teflon® barrier seal provides a first line of defense, prolonged running of the pump with a leaky seal can destroy the ball bearings resulting in catastrophic pump failure and engine shut-down.

For seal replacement, the pump must be removed from the engine and disassembled in order to gain access to the seal area. Where mechanical seals are used, both components (stationary and rotating member) must be replaced at the same time. Lip seals must be pushed out of their press-fitted position and new seals pressed into place, using a sealant on the outside of the lip seal housing.

Refer to exploded view drawings for seal location and part numbers for ordering purposes.

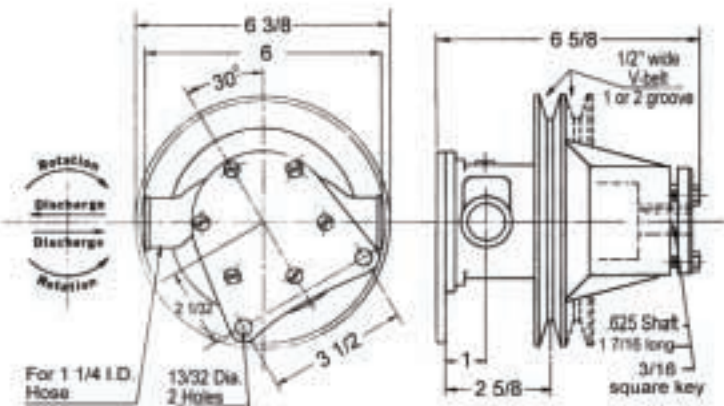

Note: For 2 groove pulley, see 402M-06 (7562) - consult factory